

### Sodium Inspection Light



KNL-35D



KNL-55D

#### Wavelength Spectral Characteristics

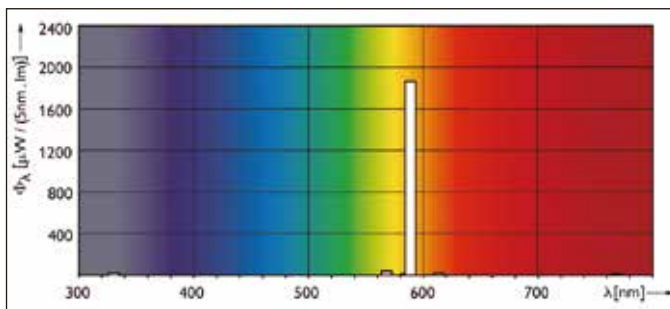

#### Interference Fringes



#### Examples of Inspection Applications

- TFT, LCD Surface Interference Fringe.
- Measurement of Cell Gap in Surface Inspection.
- TFT LCD Surface Interference Fringe Inspection.
- Inspection of Bubbles, Foreign Objects, Dust, Fingerprints, etc.

Adjustable Irradiation Angle



### [Product Features]

- Special wavelength of 550-600nm provides eye-friendly light
- Variable irradiation distance from 350-600mm
- Adjustable irradiation angle from 0-90°
- Uses an electronic stabilizer with minimal flicker
- Custom base-less designs are also available upon request

### Specifications

	KNL-35D	KNL-55D
Power Supply	AC90V~115V	AC90V~115V
Light Emission Size	345×245mm	560×440mm
Stage Size	453×363mm	545×455mm
Light Source	Sodium Lamp	Sodium Lamp
Lamp Output	35W	55W
Lamp Lifetime	9000Hours	9000Hours
Weight	12 Kg	18 Kg

### Dimensional Diagram

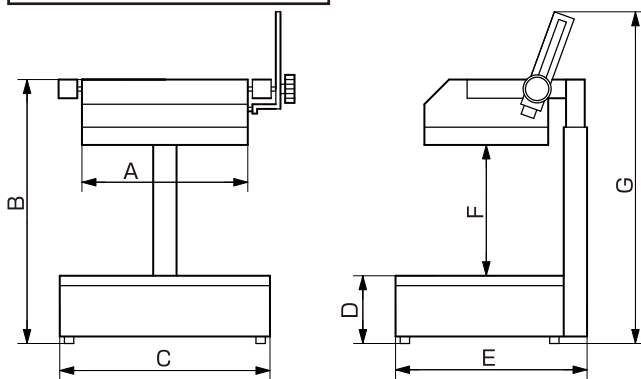

### Dimensions of Each Part Unit: mm

	KNL-35D	KNL-55D
A	355	560
B	635	650
C	450	550
D	145	150
E	410	510
F	350~600	350~600
G	780 (minimum state)	830 (minimum state)

